



The power behind competitiveness

Delta PQC Series Wall-Mounted Static VAR Generator (SVG)

User Manual

Save This Manual

This manual contains important instructions and warnings that you should follow during the installation, operation, storage and maintenance of this product. Failure to heed these instructions and warnings will void the warranty.

Copyright © 2015 by Delta Electronics Inc. All Rights Reserved. All rights of this User Manual ("Manual"), including but not limited to the contents, information, and figures are solely owned and reserved by Delta Electronics Inc. ("Delta"). The Manual can only be applied to the operation or the use of this product. Any disposition, duplication, dissemination, reproduction, modification, translation, extraction, or usage of this Manual in whole or in part is prohibited without the prior written permission of Delta. Given that Delta will continuously improve and develop the product, changes may be made to the information in this Manual at any time without obligation to notify any person of such revision or changes. Delta will make all possible efforts to secure the accuracy and the integrity of this Manual. Delta disclaims any kinds or forms of warranty, guarantee, or undertaking, either expressly or implicitly, including but not limited to the completeness, faultlessness, accuracy, non-infringement, merchantability or fitness for a particular purpose of the Manual.

Table of Contents

Chapter 1 : Important Safety Instructions	1
1.1. Safety Precautions	1
1.2. Wiring Warnings	1
1.3. Usage Warnings	2
1.4. Storage Precautions	2
1.5. Symbols	2
Chapter 2 : Introduction	3
2.1 Product Introduction	3
2.2 PQC Series SVG Wall-mounted Module Category	4
2.3. Functions & Features	6
2.4. Mechanism & Appearance	7
2.4.1 Wall-mounted Module Appearance and Dimensions	7
2.4.2 LCM (Liquid Crystal Monitor)	9
2.4.3 HMI (Touch Panel Human Machine Interface)	11
2.5. Package Inspection	13
Chapter 3 : Installation and Wiring	14
3.1 Pre-installation Confirmation	14
3.2 Installation Environment	14
3.3 Installation of the Wall-mounted Module	16
3.4 Installation of the LCM	17
3.5 Installation of the HMI	18
3.6 Wiring of the Wall-mounted Module	19
3.7 CT Installation & Wiring	19
3.7.1 CT Selection	19
3.7.2 Basic CT Installation & Wiring	21
3.7 Wiring Communication Terminals	21
Chapter 4 : SVG Operation Procedures	24
4.1 Inspection Before Start-up	24
4.2 Start-up Procedures	25

Chapter 5 : Display and Settings	26
5.1 Description of LCM Display	26
5.2 LCM Display Hierarchy	27
5.3 Description of HMI Display	28
5.4 HMI Display Hierarchy	29
Chapter 6 : Maintenance	30
Chapter 7 : Troubleshooting	31
Chapter 8 : Warranty	32

Chapter 1 : Important Safety Instructions

1.1. Safety Precautions

- The Static VAR Generator (SVG) is designed for industrial applications. It shall be connected to a power grid system, in parallel with loads, as a solution to compensate reactive power.
- The SVG shall not be exposed to rain or wet conditions, and shall be away from any flammable fluid, gas or explosives.
- Adequate space shall be left at the top and bottom of the SVG for well ventilation and convenient maintenance.
- To minimize fire and electric shock hazards, installation must be conducted by qualified service personnel in a controllable working environment.
- To minimize electric shock hazards, all maintenance work must be carried out by qualified technician. Before maintenance, ensure that all power supply is completely cut off.
- High voltage hazards! It takes over 15 minutes for the DC capacitor to discharge. Please make sure the device has discharged completely before carrying out any operation.
- To minimize electric shock hazards, please read this Manual carefully before switching the power on, and keep this Manual properly for permanent reference.
- When the SVG is used in IT applications, please install an insulation resistance detection device so that the alarm will go off when a protection earth fault is detected.

1.2. Wiring Warnings

- To prevent a possible risk of current leakage, the SVG shall be earthed properly.
- With regard to wiring, the compensation capacity and the current-carrying capacities of cables shall be taken into account.
- The incoming lines of the SVG shall be connected with appropriate protective devices, for instance, a breaker. Besides, take the installation position of the equipment into consideration and choose the protective devices with adequate breaking capacity.
- The capacity of the protective device shall fit that of the SVG.
- To prevent scaling caused by high temperature, after the power is cut off, the operating switch shall be allowed to cool down before being operated again.
- The three-phase, four-wire SVG is applicable to the power grid system with neutral grounding.



1.3. Usage Warnings

- Since the SVG is used for reactive power compensation of the power grid, the capacity selection of the SVG shall be subject to the required reactive power to avoid poor compensation due to insufficient capacity.
- Since the SVG is used for reactive power compensation, it shall be connected to an external CT for current detection (CT: Current transformer).
- To guarantee sound reliability and avoid overheating, do not block or cover the air inlet and outlet of the SVG.
- The working temperature range of wall-mounted SVG is -10°C to 55°C, SVG starts to de-rate from 50°C, and SVG will not work when ambient temperature exceeds 55°C.
- The SVG system shall be installed at a place with altitude less or equal 1,000m. Please de-rate SVG capacity or consult Delta or Delta distributor if the altitude limit is exceeded.
- When installation, ensure that the height from the ground to the top of the SVG is not less than 1800mm. After installation, ensure that no objects are placed on the SVG's air outlet; otherwise, the objects might drop into the air outlet to influence the SVG ventilation and operation.

1.4. Storage Precautions

- Please use the original packing material to protect the SVG in order to avoid damage by rodents.
- If you don't install the SVG immediately after receiving it, please store the SVG in a dry and ventilated indoor place, where shall be maintained between -40°C and 70°C with relative humidity no higher than 95%.

1.5. Symbols

Item	Symbol	Description
1	R	Phase R of three-phase power supply
2	S	Phase S of three-phase power supply
3	T	Phase T of three-phase power supply
4	N	Neutral line
5		Main grounding terminal
6		E.P.O button (Emergency Standby)

Chapter 2 : Introduction

2.1 Product Introduction

The Static VAR Generator (SVG) is a reactive power compensation device, it is used for reactive power compensation for the three-phase power grid. The device has the following characteristics:

- Compensates both inductive and capacitive reactive power.
- Correct three phase load imbalance.
- Rapid dynamic responses, stable parameters and good reactive power compensation results.
- The unit offers high efficiency and low wear and tear. Under the advanced ECO energy saving mode, the unit can operate smarter while consuming less power..
- The system adopts an advanced 3-level structure and consists of digital signal processors (DSP), large programmable controllers and high power electronic devices, which has excellent performance and superior reliability.
- Supports remote power on/ off functions via computer monitoring.

Please see *Figure 2-1* for the SVG block diagram. The SVG system is composed of a wall-mounted SVG module (with a Bracket to support wall-mounting structure and provide protection), and a Display. There are two types of Displays, one is Touch Panel HMI (HMI), which is touch-screen type, and the other one is non-touch-screen type, called Liquid Crystal Monitor (LCM).

The external CT is used for detection of load current and feedback to wall-mounted SVG module. Based on load current feedback, the controller manages power circuit to output inverse reactive current to cancel out load reactive power..

Please note that the wall-mounted SVG module, the Display and the Bracket are packed separately, so you should purchase them separately.

The wall-mounted SVG module can work either alone or in parallel with others. The HMI or LCM monitors and controls the wall-mounted SVG module online, one HMI or LCM is able to monitor multiple wall-mounted SVG modules.

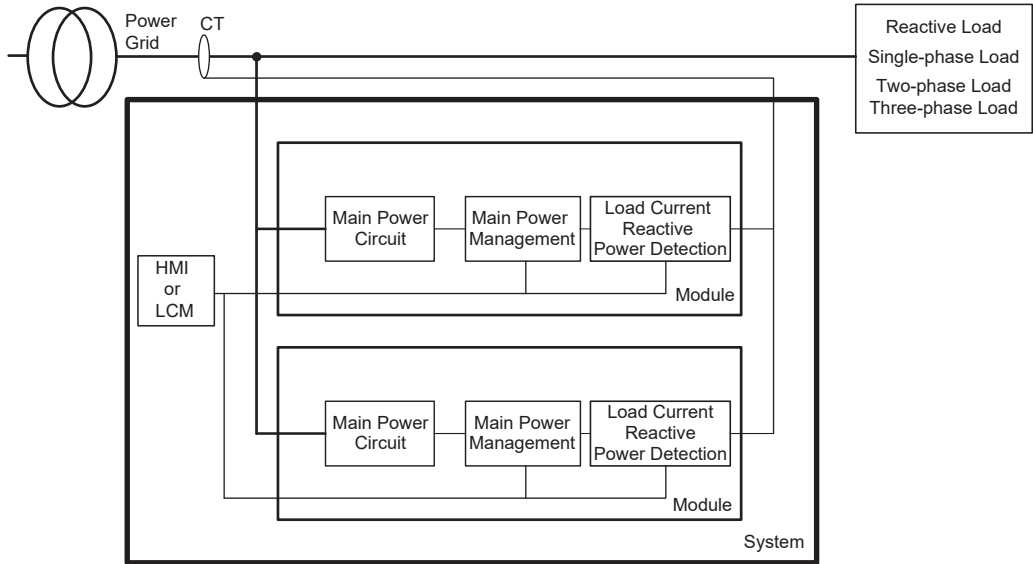

(Figure 2-1: SVG System Block Diagram)

2.2 PQC Series SVG Wall-mounted Module Category

The PQC series SVG product includes the wall-mounted module, the Display and the wall-mounted Bracket. **Table 2-1** lists the wall-mounted SVG module's model, capacity and wiring system, as well as LCM, HMI and Bracket information.

Table 2-1: PQC Series SVG Wall-mounted Module Specifications

Product	Model	Capacity	System
Wall-mounted SVG Module	PQCS-400-50-50WM4	50Kvar	3P4W
LCM	PQC-LCM-W	N/A	N/A
HMI	PQC-HMI-W	N/A	N/A
Wall-mounted Bracket	3313192900-SP	N/A	N/A

The SVG's wall-mounted SVG module is available in one wiring type, i.e. 3P4W, and is available in one specifications in terms of the reactive power compensation capacity, i.e. 50Kvar. The 3P4W module shall be connected to the neutral line, and it is able to compensate the current of neutral line, such as zero sequence fundamental. **Figure 2-2** shows the SVG's wall-mounted module.

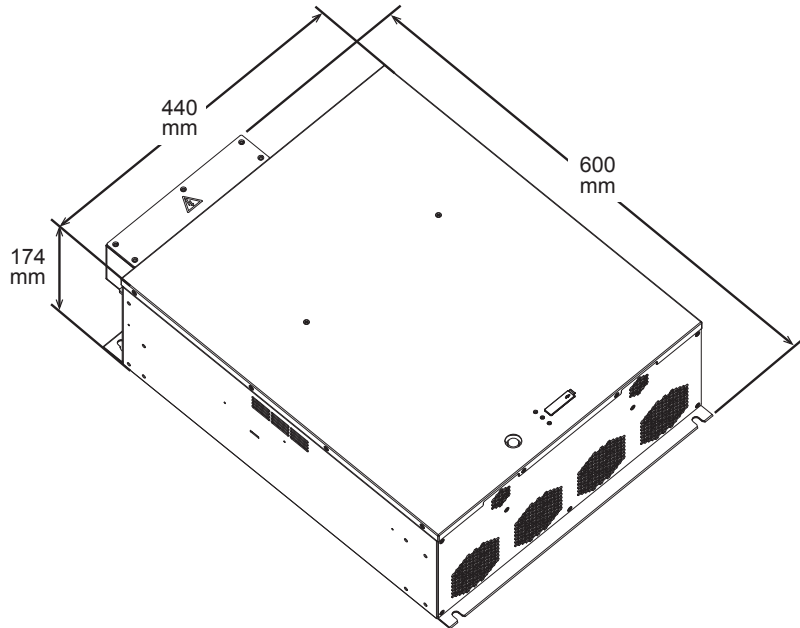

(Figure 2-2: PQC Series Wall-mounted SVG Module)

Use the provided communication connection cable (along with the HMI or LCM) to connect the HMI or LCM's DATABUS port and the wall-mounted SVG module's communication terminals. After that, you can use the HMI or LCM to monitor the operation status of the wall-mounted SVG module and set up relevant parameters. **Figure 2-3** shows the HMI appearance and **Figure 2-4** shows the LCM appearance.

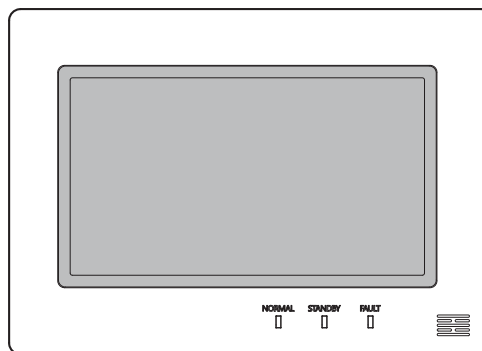

(Figure 2-3: HMI)

2.3. Functions & Features

- Multifunction: the SVG can simultaneously realize the purposes of reactive power and three-phase unbalance compensation.
- Superb compensation performance: The system's reactive power compensation rate can be as high as 98%.
- Excellent compensation of reactive power: the device can realize rapid (ms-grade response), precise ($-0.99 < PF < 0.99$) and bi-directional (both capacitive and inductive compensations) reactive power control.
- Outstanding compensation of unbalanced three-phase: the device can realize correction for either active or reactive unbalance, and can eliminate the neutral current.
- Wide input voltage and frequency ranges, suitable for the applications with diesel generators and harsh power supply conditions, line voltage: 308V ~ 456V.
- Low power loss (lower than 3% of rated device capacity) and actual efficiency > 97%.
- Sound stability: the device acts as an infinite impedance to the power grid system and has no effect on the impedance of the power grid system; it is able to produce accurate and flawless output waveform, which has no effect on other equipment.
- Applicable to all work conditions: the device is able to operate under high temperature up to 55°C and salt spray corrosive conditions, can withstand grade-9 seismic intensity and is compatible with the diesel engine generating system.
- User-friendly interface (in both Chinese and English): event log, automatic fault alarm, alarm history and other parameter setting functions.
- Complete functions: automatic self-checking start, settable soft start time, emergency standby function (E.P.O), etc.



(Figure 2-4: LCM)

2.4. Mechanism & Appearance

2.4.1 Wall-mounted SVG Module Appearance and Dimensions

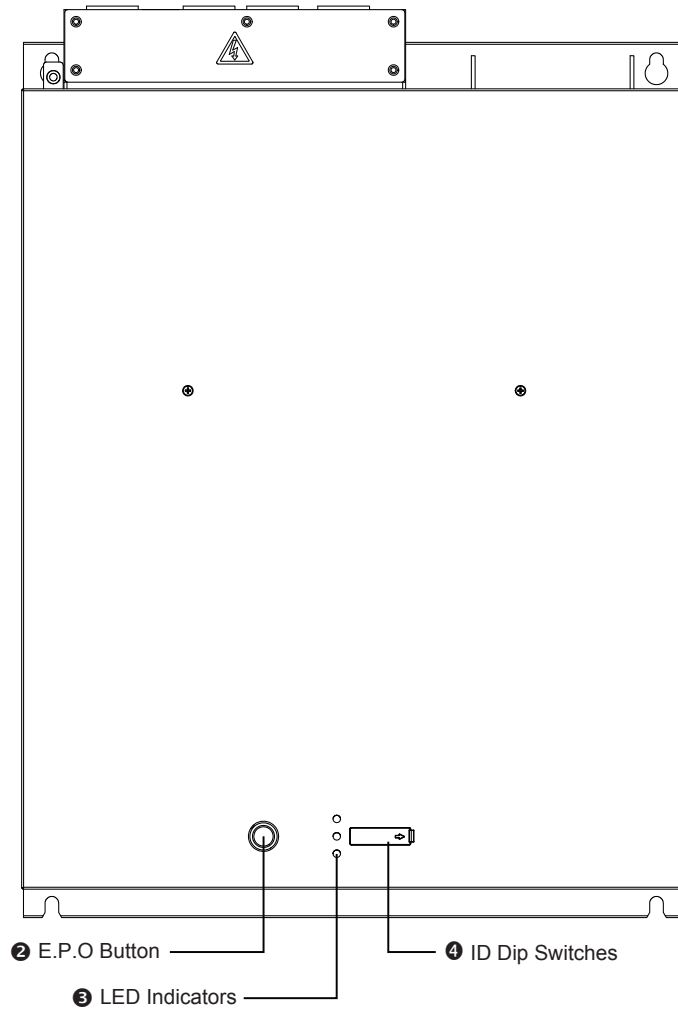

(Figure 2-5: PQC Series Wall-mounted SVG Module_Front View)

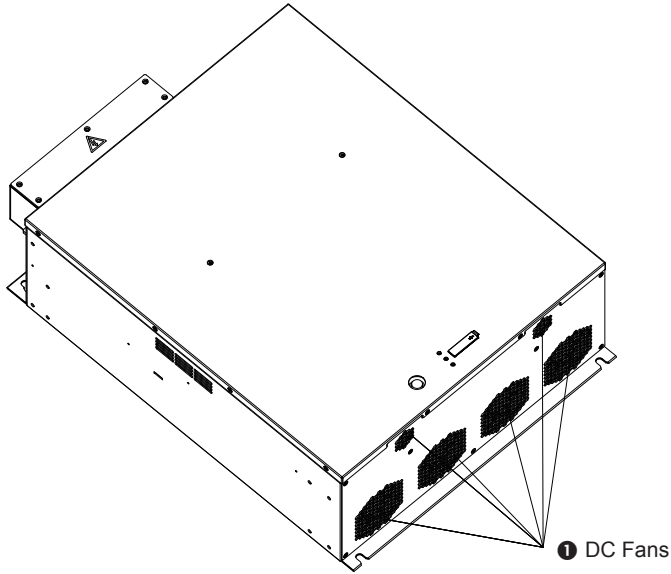

(Figure 2-6: PQC Series Wall-mounted SVG Module _Side View)

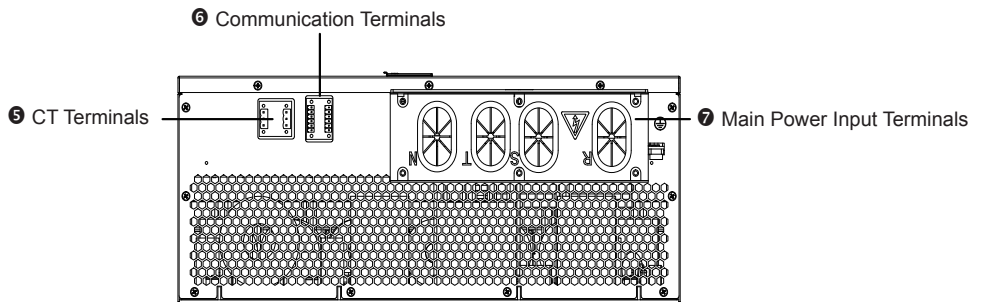

(Figure 2-7: PQC Series Wall-mounted SVG Module _Top View)

No.	Item	Description
①	DC Fans	Heat dissipation DC fans.
②	E.P.O	Emergency Standby button.
③	LED Indicators	Wall-mounted module's status indicators: <ul style="list-style-type: none"> • Green (normal): Normal. • Yellow (standby): Standby • Red (fault): Fault
④	ID Dip Switches	Please refer to Chapter 4: SVG Operation Procedures.
⑤	CT Terminals	For CT signal.
⑥	Communication Terminals	For communication signal.

No.	Item	Description
7	Main Power Input Terminals	For main power input wiring (R/ S/ T/ N/ PE).

Table 2-2: PQC Series Wall-mounted SVG Module Dimensions & Weight

Model	Dimensions (W*H*D)	Weight
PQCS-400-50-50WM4	440×600×174mm	30kg

2.4.2 LCM (Liquid Crystal Monitor) Display

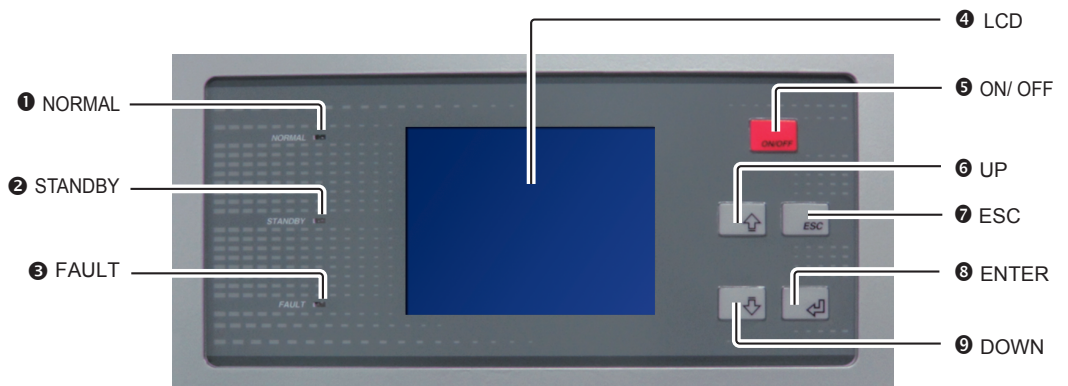

(Figure 2-8: LCM_ Front View)

No.	Item	Description
①	NORMAL LED (green)	Illuminates when the SVG system is normal.
②	STANDBY LED (yellow)	Illuminates when the SVG system is in standby.
③	FAULT LED (red)	Illuminates when the SVG system has abnormalities.
④	LCD Display	Displays both Chinese and English fonts.
⑤	ON/ OFF Key	Press and hold the key for 3 seconds to switch on/ off the SVG system.
⑥	UP Key	Press the key to move the menu items upward or to increase the parameter setting value.
⑦	ESC Key	Press the key to return to the previous menu or to save the parameter setting when exit.
⑧	ENTER Key	Press the key to go to the next page or to confirm the parameter setting.
⑨	DOWN Key	Press the key to move the menu items downward or to reduce the parameter setting value.



(Figure 2-9: LCM_ Rear View)

No.	Item	Description
①	DATABUS	The communication interface between the LCM and the wall-mounted module.
②	RS232	The standard RS232 interface.
③	Dry/ Wet Contact	Dry and wet contact terminals.
④	SPD Status	Cabinet's SPD (Surge Protection Device) status feedback terminal.
⑤	E.P.O Status	Cabinet's E.P.O (Emergency Standby) button status feedback terminal.

2.4.3 HMI (Touch Panel Human Machine Interface) Display

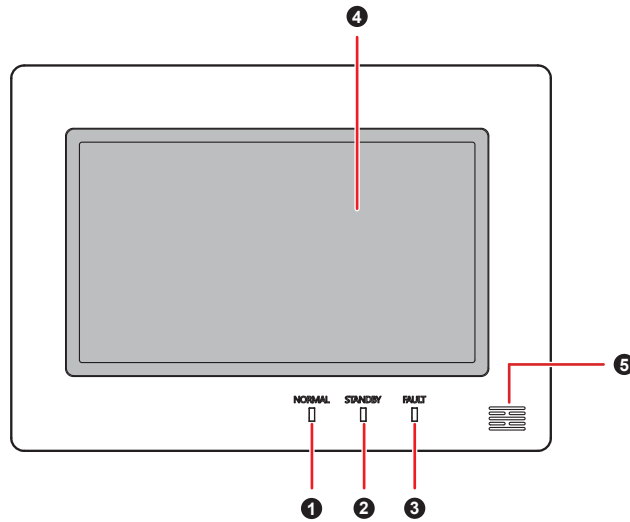

(Figure 2-10: HMI_ Front View)

No.	Item	Description
①	NORMAL(Green)	Illuminates when the SVG system is normal.
②	STANDBY(Yellow)	Illuminates when the SVG system is in standby status.
③	FAULT(Red)	Illuminates when the SVG system has abnormalities.
④	Touch Screen	Data display and parameters setting.
⑤	Buzz	Sound alarm.

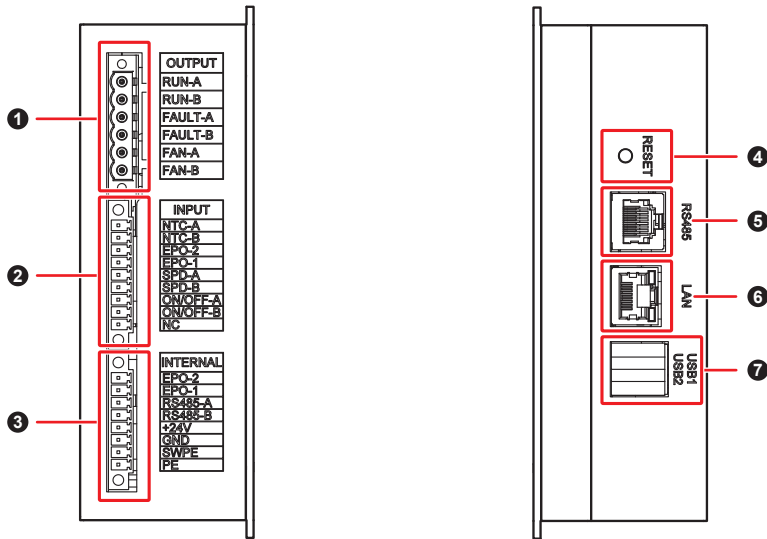

(Figure 2-11: HMI_ Side View)

No.	Item	Description
①	Output Signal	Output system information such as run/ standby status, etc.
②	Input Signal	Input remote control instruction, etc.
③	Modbus	Communication Terminal between HMI and SVG module.
④	RESET	Reset HMI.
⑤	RS485	Standard RS485 interface.
⑥	LAN	Standard Ethernet interface.
⑦	USB	Standard USB interface.

2.5. Package Inspection



NOTE:

The SVG system includes the wall-mounted SVG module, LCM / HMI and Bracket, which are packed separately. And they should be separately purchased.

- **Exterior**

Some unpredictable situations might occur during transportation. It is recommended that you inspect the exterior packaging after receiving the wall-mounted SVG module, LCM/ HMI and Bracket. If you notice any damage, please contact your supplier.

- **Interior**

1. Please check the rating labels of the wall-mounted SVG module and the LCM/ HMI to see if the products conform to your order.
2. Please check if any parts are damaged or loose.
3. Please check if the accessories are complete.
4. Please see the tables below for the standard accessories of the wall-mounted SVG module and the LCM/ HMI.
5. If any damage is found, please contact your supplier.
6. To return goods, please use the original packing material to pack the wall-mounted SVG module, the LCM/ HMI, the Bracket and all standard accessories.

Table 2-3: Standard Accessories of the Wall-mounted SVG Module

No.	Item	Quantity
①	CT Terminal Block (3-pin)	2 PCS
②	Communication Terminal Block (6-pin)	2 PCS
③	Main Power Input Terminal_ R/ S/ T/ N	4 PCS
④	PE Terminal	1 PC
⑤	Terminal Screw M6*12L	5 PCS

Table 2-4: Standard Accessories of the LCM / HMI

No.	Item	Quantity
①	Fastening Screw	5 PCS (LCM)
		4 PCS (HMI)

Chapter 3 : Installation and Wiring

The SVG is applicable to many applications and can meet the particular installation requirements of industrial sites, power distribution rooms and computer rooms. The wall-mounted SVG module can be installed on a load-bearing wall or in a cabinet.

3.1 Pre-installation Confirmation

Since the installation environment varies for different users, please read this Manual carefully before installation. All installation, assembly and start-up work must be carried out by qualified professional personnel. If you want to carry out installation, assembly and start-up work by yourself, it shall be under the supervision of qualified professional personnel.

3.2 Installation Environment

1. The SVG device can only be installed indoors. Do not install the device for outdoor use. Be sure to consider the IP21 protection degree of the wall-mounted SVG while installing. For a higher protection degree requirement, please contact your distributor.
2. The SVG device shall not be installed in a place close to dust sources or subject to heavy environmental pollution. Since the conductive dust will damage the device, make sure the installation place is free of conductive dust.
3. Make sure installation and supporting components are capable of bearing weight of SVG.
4. Since some noise can be generated during the operation of the SVG, please take the noise effects into account when choosing the installation position.
5. Keep the installation area clean. Please note that wiring routes must be hermetic to prevent possible damage from rodents.
6. Make sure that enough space is left in the installation area for maintenance. When installation, ensure that the height from the ground to the top of the wall-mounted SVG is not less than 1800mm. This avoids any object from being placed on the top of the SVG and from dropping into the SVG.
7. Since some heat can be generated during the operation of the SVG, please make sure the cooling system of the installation environment is sufficient for heat dissipation, so that the ambient temperature will not exceed the normal working temperature of the device.
8. The device is equipped with cooling fans, and is designed with air inlet at the bottom and air outlet on the top as well as on the sides; thus, it is recommended to leave at least a 500mm space both on the top and at the bottom, and some ventilation space on the sides of the SVG for ventilation purpose. *Figure 3-1* illustrates the air inlet & outlet schematic diagrams of the SVG.

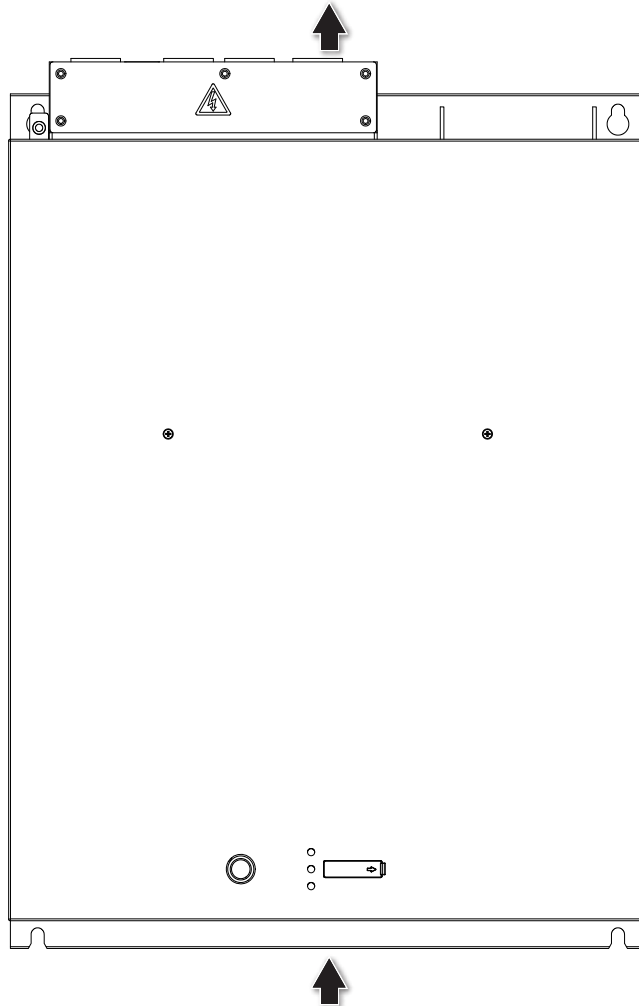

(Figure 3-1: Air Inlet & Outlet Schematic Diagrams of the SVG)

9. The SVG has a minimum vent flow requirement, which shall be met to guarantee the normal cooling of the device. For the SVG mounted in a cabinet, please ensure the cabinet has sufficient vent flow to cool the device.
10. The working temperature range of wall-mounted SVG is -10°C to 55°C , SVG starts to de-rate from 50°C , and SVG will not work when ambient temperature exceeds 55°C .
11. The SVG system shall be installed at a place with altitude less or equal 1,000m. Please de-rate SVG capacity or consult Delta or Delta distributor if the altitude limit is exceeded.
12. The SVG's main power input terminals are covered by the protection covers. Before removing the protection covers or wiring, please ensure that the power is off. Before powering on, make sure the protection covers are re-installed.

3.3 Installation of the Wall-mounted Module

When the wall-mounted SVG module needs to be installed in a cabinet, ensure that the cabinet has the design of air inlet at the bottom and air outlet on the top. Please rivet or weld the M8 hexagon nuts (not provided; Q'ty: four) on the cabinet's four pillars, and then use the M8*16 hexagon socket head bolts (not provided; Q'ty: four) to install the wall-mounted module into the four pillars' M8 hexagon nuts.

When the wall-mounted SVG module needs to be installed on a wall, ensure that the wall is constructed by the reinforced concrete and is capable of bearing the weight of the module. The use of 4 pieces of M6 stainless steel expansion bolts are suggested for installation. When installation, ensure that the height from the ground to the top of the wall-mounted module is not less than 1800mm.

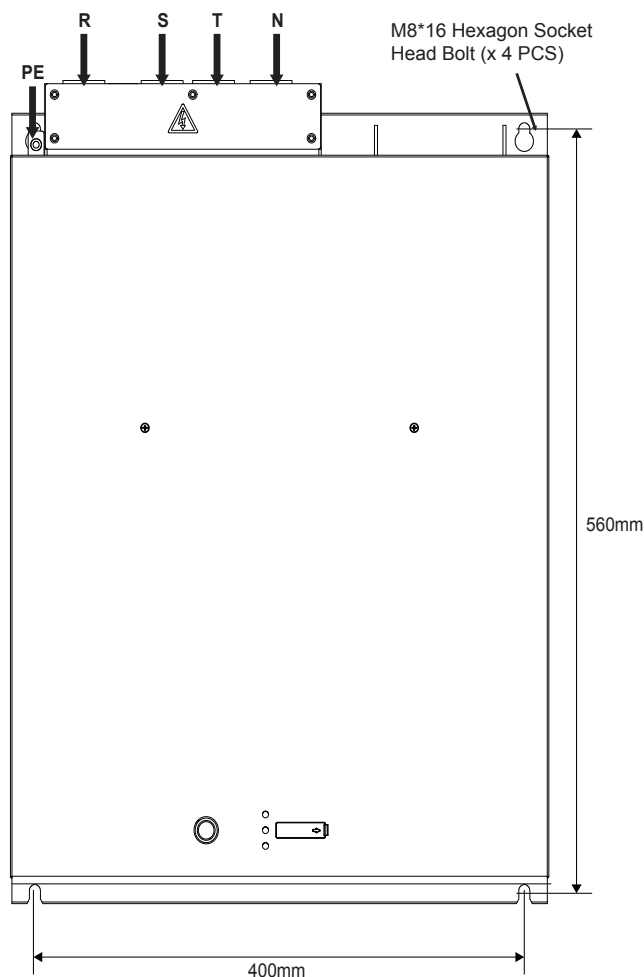

(Figure 3-2: Wall-mounted Module Installation Dimensions_ Front View)

3.4 Installation of the LCM

When installation, please use the provided fastening screws (packed in the LCM package) to install the LCM into the mounting holes of the customer provided panel. After installation, use the provided LCM connection wire (along with the LCM) to connect the LCM's DATABUS port and the wall-mounted SVG module's communication terminals.

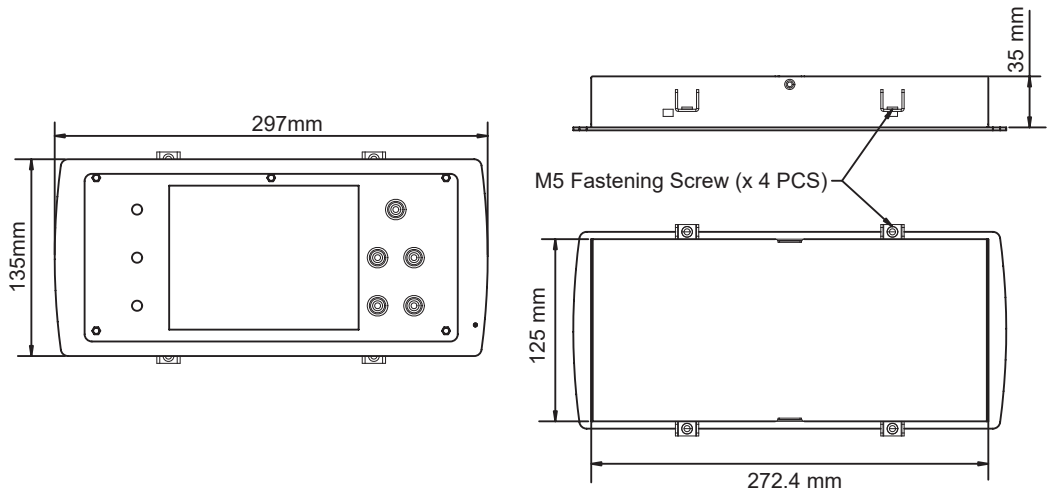

(Figure 3-3: LCM Structure & Dimensions)

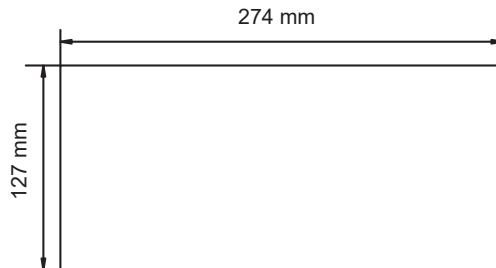

(Figure 3-4: Mounting Hole Dimensions of the LCM)

3.5 Installation of the HMI

When installation, please use the provided fastening screws (packed in the HMI package) to install the HMI onto the wall-mounted SVG module. After installation, use the provided HMI connection wire (in HMI package) to connect the HMI's DATABUS port and the wall-mounted SVG module's communication terminals.

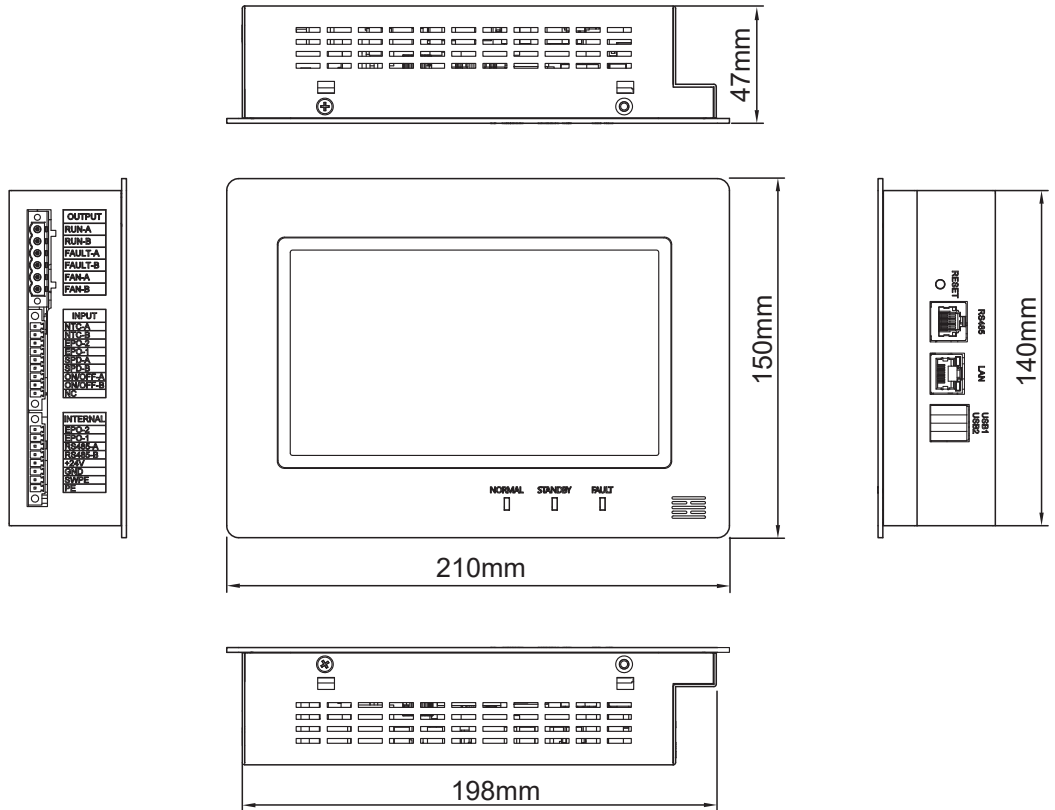

(Figure 3-5: HMI Structure & Dimensions)

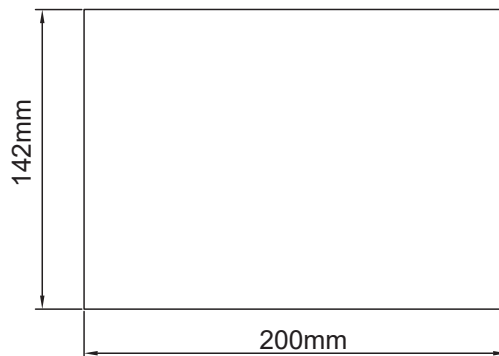

(Figure 3-6: Mounting Hole Dimensions of the HMI)

3.6 Wiring of the Wall-mounted Module

1. Before connecting the cables or electronics, please be sure to cut off the input power of the wall-mounted SVG module to avoid accidents.
2. The wall-mounted SVG module must be grounded properly to avoid any possible damage caused by current leakage. Check the diameter marking of the wall-mounted SVG module's input wires, and make sure the wire diameter and phase sequence are correct. Please refer to **Table 3-1** for the specifications of the power lines and **Table 3-2** for the tightening torque.

Table 3-1: Wall-mounted SVG Module's Power Line Specifications

Wall-mounted SVG Module Rating	50Kvar
Wire Diameter_ R/S/T	35 mm ²
Wire Diameter_ N	35 mm ²
Wire Diameter_ PE (protective earthing)	16 mm ²
Breaker Rated Current	100A

Table 3-2: Wall-mounted SVG Module's Power Line Tightening Torque

Bolt Size	Torque Value (N-m)
M6	8

3.7 CT Installation & Wiring

3.7.1 CT Selection

1. The appropriate rated ratio of primary to secondary current shall be determined. The primary current is recommended to be 1.5*In (the actual rated current).
2. The rated voltage is 0.5KV or 0.66KV.
3. The secondary current is 5A or 1A.
4. CT accuracy shall be 0.5 or 1.0 class.
5. The secondary capacity (rated load) of CT shall meet requirement of secondary impedance (≥5VA when secondary current is 5A). The capacity and the maximum one-way wiring length from the CT to SVG shall be calculated according to following formula:

Wherein:

$$L_{max} = \frac{P_{CT} - P_1}{I^2} \cdot \frac{S}{\rho} \cdot \frac{1}{2}$$

Wherein:

L _{max} :	the maximum one-way wiring length from the CT to the wall-mounted module (m);
P _{CT} :	the nominal secondary capacity of the CT (VA);
P ₁ :	the capacity loss caused by the internal impedance of the wall-mounted module and the contact resistance (about 0.08Ω, when the secondary current is 5A, the loss is about 2VA in total);
I:	the secondary current of the CT (A);
S:	the cross-section area of the copper conductor (mm ²);
ρ:	the resistivity of the copper wire (calculate according to 0.0178 Ω x m/ mm ²);

Take I=5A as an example, refer to the following table for quick CT selection.

Table 3-3: Quick CT Selection

CT Ratio	CT Primary Current : 5A CT Primary Current ≥ 1.5* Maximum Load Current
CT Accuracy	Class 0.5 or 1.0
CT Secondary Capacity (VA)	1~2 Modules: ≥ 10VA
	3~4 Modules: ≥ 15VA
	5~7 Modules: ≥ 20VA
	>7 Modules, consult Delta or Delta distributor

3.7.2 Basic CT Installation & Wiring

The CT for current detection shall be located on either grid side or load side, to feed the detection signal to the SVG. The wall-mounted SVG module's CT terminals is shown in **Figure 3-7**.

- A set of CT must be provided for current detection at either grid side or load side.
- The CTs must be connected accurately.
- The phase sequences of the detection signal of the CTs must not be exchanged.
 1. The secondary output S1 of CT1 for R-phase detection must be connected to the CT terminal R-S1, and the S2 outgoing line must be connected to the CT terminal R-S2.
 2. The secondary output S1 of CT2 for S-phase detection must be connected to the CT terminal S-S1, and the S2 outgoing line must be connected to the CT terminal S-S2.
 3. The secondary output S1 of CT3 for T-phase detection must be connected to the CT terminal T-S1, and the S2 outgoing line must be connected to the CT terminal T-S2.

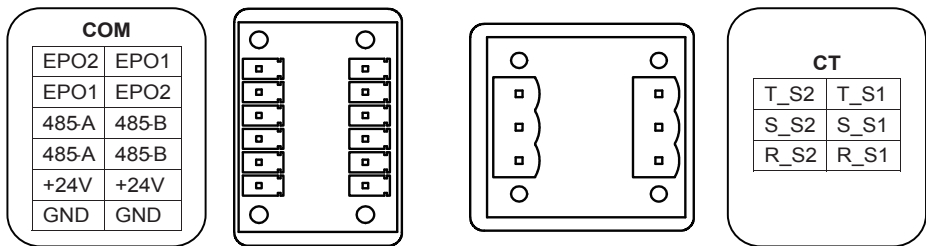

(**Figure 3-7: Communication Terminals and CT Terminals on the Wall-mounted Module**)



NOTE:

Hazards! The CT terminals at customer side have high voltage! Do not touch them with your bare hands. Before wiring or removal of power lines, turn off the wall-mounted module and short the customer's CT terminals.

For basic CT wiring diagram, please refer to **Figure 3-8 To Figure 3-11**. CT Connection of SVG has a lot of variations, please consult Delta or Delta's distributor for more details.

3.8 Wiring Communication Terminals

Please see **Figure 3-7** for the locations of the communication terminals on the wall-mounted module. One row of the communication terminals can be connected to the LCM/ HMI, and the other row of the communication terminals can be connected to another wall-mounted SVG module to establish a parallel system.

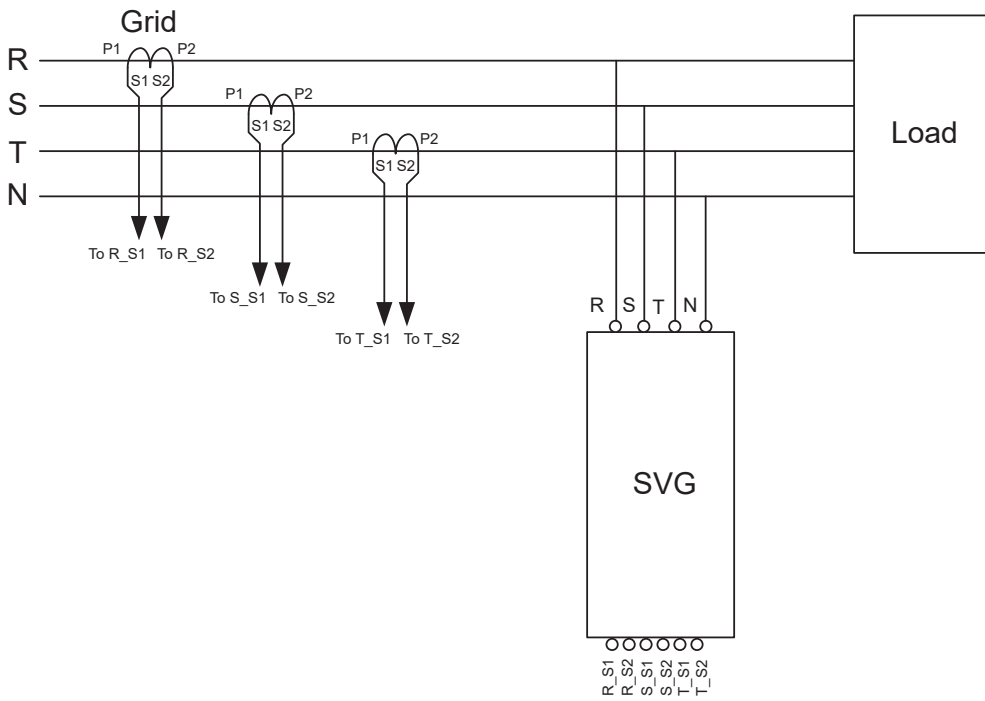

(Figure 3-8: Closed loop CT installation and wiring_3 CTs)

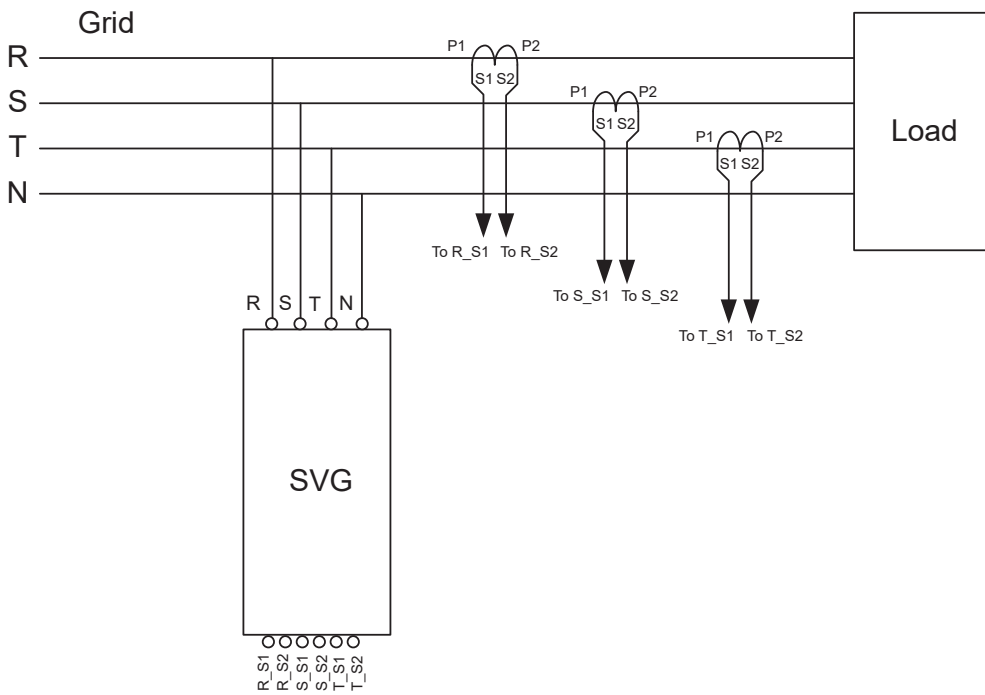

(Figure 3-9: Open loop CT installation and wiring_3 CTs)

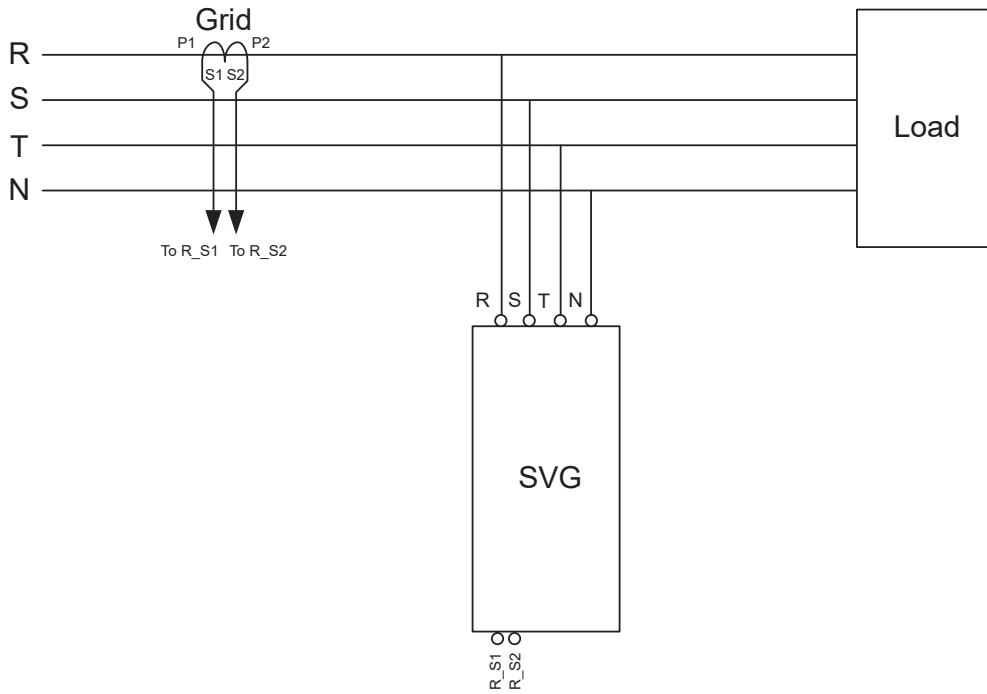

(Figure 3-10: Closed loop CT installation and wiring_1 CT)

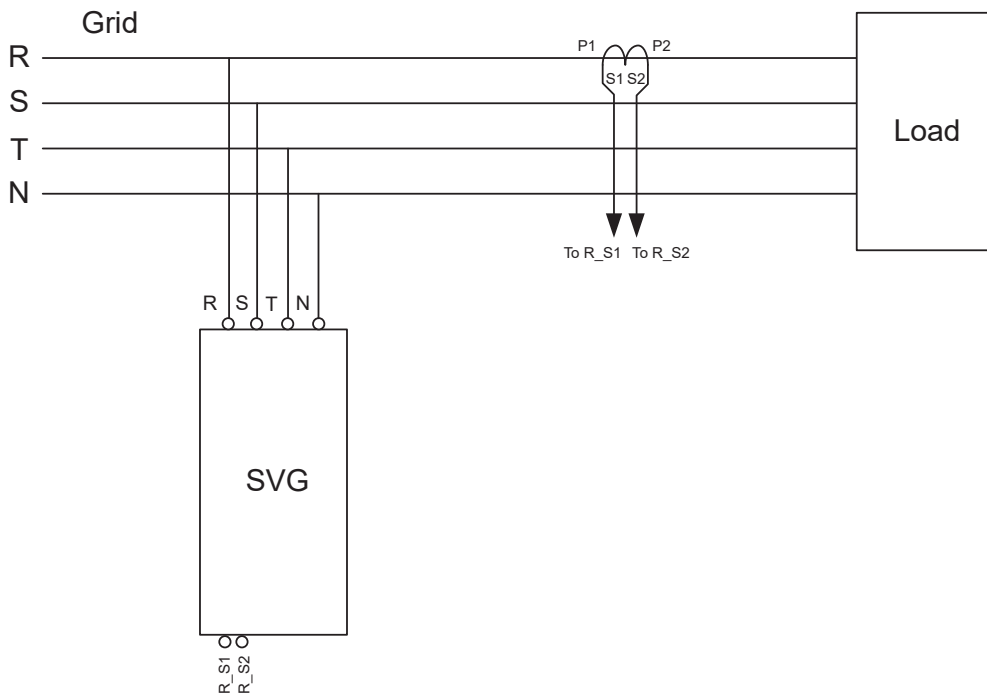

(Figure 3-11: Open loop CT installation and wiring_1 CT)

Chapter 4 : SVG Operation Procedures

4.1 Inspection Before Start-up

- Make sure each E.P.O (Emergency Standby) button in the OFF status.
- Make sure each wall-mounted SVG module's ID and terminal resistance are set properly.
- Make sure each wall-mounted SVG module's ID and terminal resistance are set properly.

The DIP switches used to set the ID and terminal resistance are as shown in **Figure 4-1**. **Table 4-1** lists the positions of DIP switches 1~4.

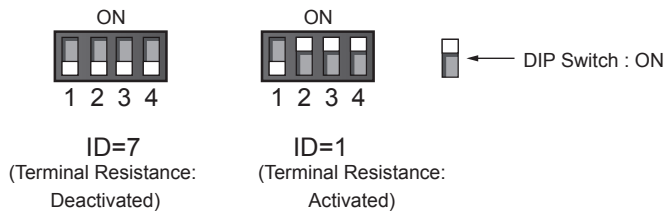

(Figure 4-1: Schematic Diagram of DIP Switches)

Table 4-1 Positions of DIP Switches

Position	Description
DIP Switch 1	Setting of the first digit of ID, which is valid when it is slid to the lower position.
DIP Switch 2	Setting of the second digit of ID, which is valid when it is slid to the lower position.
DIP Switch 3	Setting of the third digit of ID, which is valid when it is slid to the lower position.
DIP Switch 4	Setting of the terminal resistance, it is activated in lower position.

The wall-mounted module's ID setting shall be made in the sequence of 1~7.

When several SVG modules are connected in parallel, sharing same LCM or HMI, make sure that IDs of all modules are not repeated. If quantity of SVG modules is more than 4, terminal resistance DIP switch of the SVG module that locates at the farthest from the LCM/ HMI shall be set to UPPER position, and terminal resistance DIP switches of the other SVG modules shall be set to LOWER position. If SVG module quantity is less or equal 4, all terminal resistance DIP switches shall be set to LOWER position.

Refer to **Figure 4-2** for ID setting from 1~7.

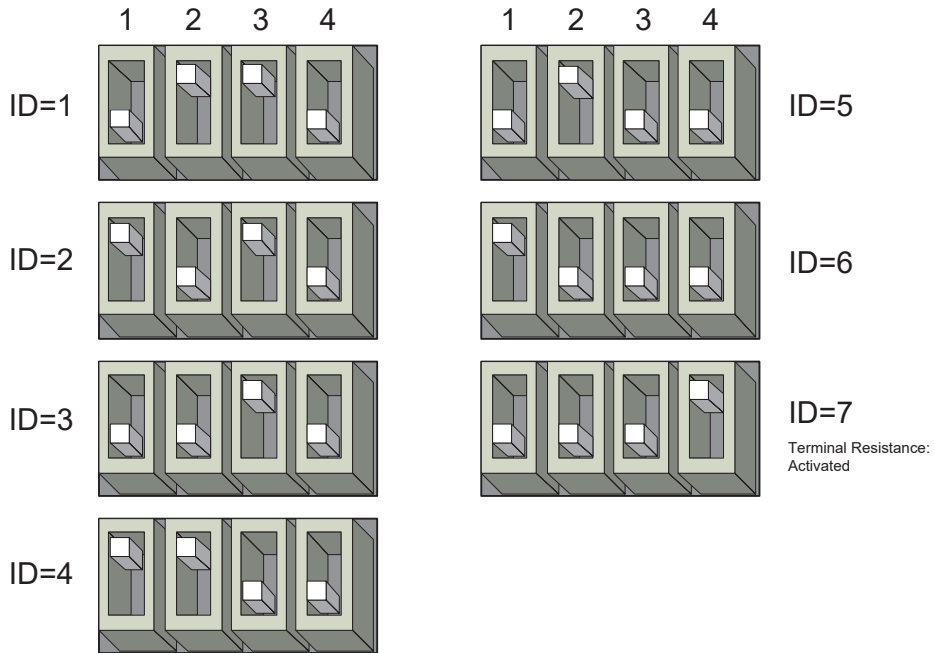

(Figure 4-2: SVG Module ID and Terminal Resistance Setting)

- The IDs of all modules are not repeated.
- The module quantity and compensation capacity are confirmed.
- The connections among each of paralleled modules are well connected.
- The connections of LCM/ HMI's DATABUS ports are well connected.

4.2 Start-up Procedures

1. Switch on main input breaker (external).
2. The internal auxiliary power supply of the modules will be started, the fans will rotate, and the yellow LED indicators in front of the modules will illuminate. After that, the LCM/ HMI will go into the Start screen, communicate with the modules, read the system messages and check if there is any fault.
3. Set the system into the operating mode. Please refer to **Chapter 5: Display and Settings** for the detailed LCM and HMI settings.
4. Press and hold the ON/ OFF button on the LCM for 3 sec, and release it after the buzzer rings. After that, the system starts up. Or Press ON/ OFF button on HMI and the system will starts up after confirmation.
5. When the system starts up and works properly, the green LED indicator on the LCM or HMI will illuminate.

Chapter 5 : Display and Settings

There are two types of SVG displays, one is Touch Panel HMI (HMI), which is touch-screen type, and the other one is non-touch-screen type, called Liquid Crystal Monitor (LCM). Both LCM and HMI monitor the SVG system parameters and display the status and settings of the system.

It is available for two levels of user: User and Service Engineer. The User level is able to directly view the detailed displayed parameters in the Measurement page. While the Service Engineer level menu is protected by password, and Setting and Maintenance pages can only be set and viewed after entering the Service password.

5.1 Description of LCM Display

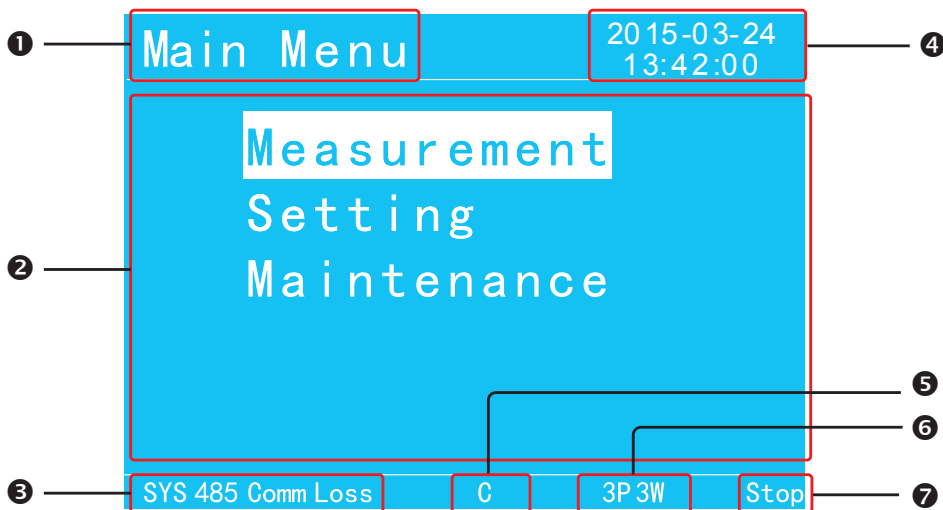

(Figure 5-1: LCM Display)

Item	Description
①	Displays the title.
②	Displays the contents relevant to the title.
③	Displays the real-time fault message of the system.
④	Displays the time of the system.
⑤	Displays the system functions (C: Compensator/ S: Reactive Power Source).
⑥	Displays the system wiring mode (three-phase three-wire/ three-phase four-wire)
⑦	Displays the system operating status (running/ stop).

5.2 LCM Display Hierarchy

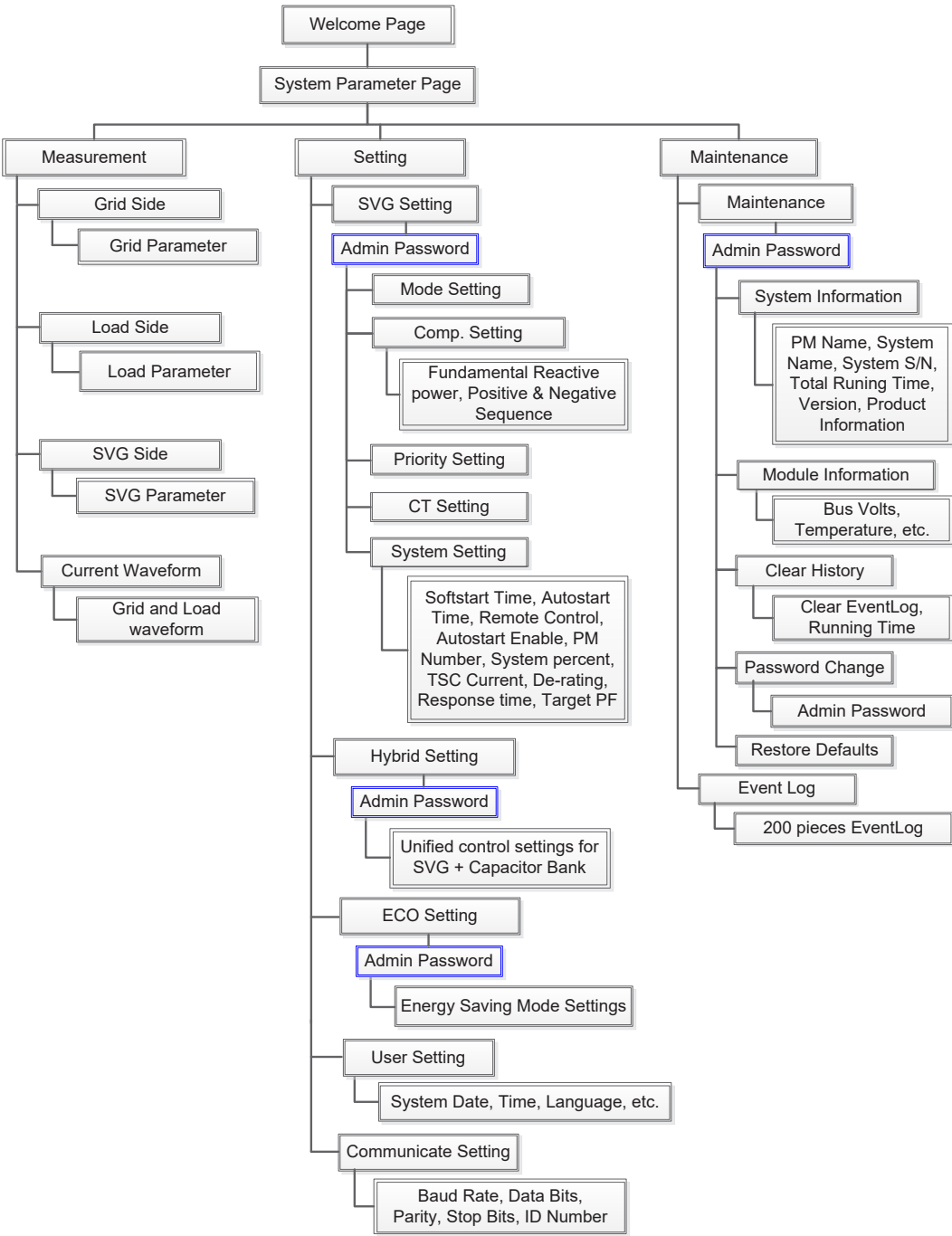

(Figure 5-2: LCM Display Hierarchy)



5.3 Description of HMI Display

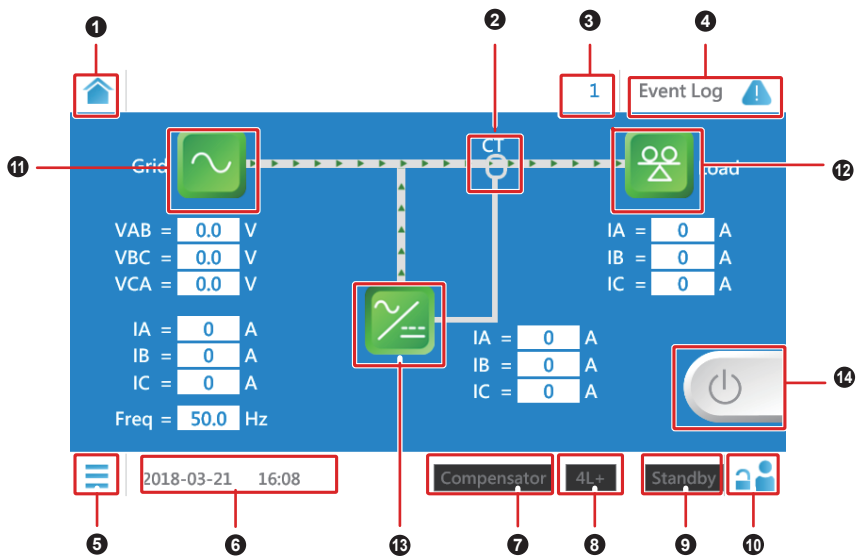

(Figure 5-3: HMI Display)

Item	Description	Item	Description
1	"Home" button, return to home page.	8	Indicate system wiring type, 3P3W or 3P4W.
2	Indicate the CT Position setting.	9	Indicate system status, Run, Standby or Fault.
3	Indicate quantity of modules connected to this HMI.	10	"Login" button, enter the "Login" page.
4	"Event Log" button, turn to "Event Log" page.	11	"Grid" button, enter the grid side data page.
5	"Menu" button, show HMI menu.	12	"Load" button, enter the load data page.
6	Display time.	13	"PQC" button, enter the SVG output data page.
7	Indicate working mode, Compensator or reactive power Source.	14	"ON/ OFF" button, turn on / off the SVG system.

5.4 HMI Display Hierarchy

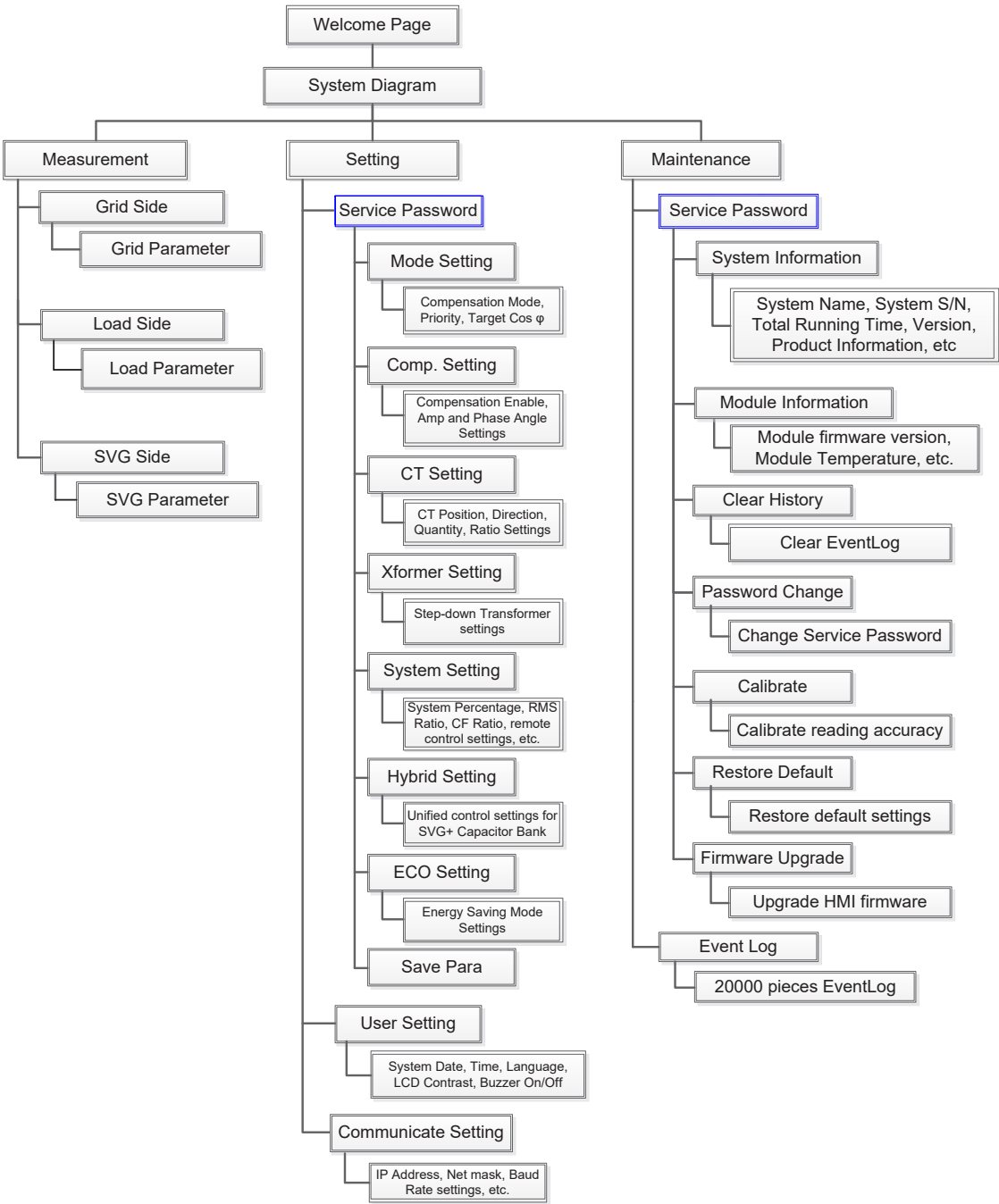

(Figure 5-2: HMI Display Hierarchy)



Chapter 6 : Maintenance

- **Cleaning of the SVG:** please contact service personnel for regular cleaning of the SVG (every 6 months; however, it is recommended that the customer clean up the dust on the baffles of air inlet and outlet every 3 months).
- **Regular inspection of the SVG:** please contact service personnel for maintenance of the SVG (every 6 months).

Chapter 7 : Troubleshooting

If any fault message or abnormality is found, please refer to the table below for the corresponding solution.

Item	Fault Message Shown on the LCM	Possible Cause	Solution
1	SYS 485 Comm Loss	<ol style="list-style-type: none"> 1. The LCM or HMI communication wire is not well connected. 2. The wall-mounted modules have repeated IDs. 	<ol style="list-style-type: none"> 1. Check if the LCM communication wire is firmly connected or not. 2. Check the DIP switches of every wall-mounted module.
2	E.P.O Fault	The E.P.O button on the wall-mounted SVG module is pressed.	Check all E.P.O buttons and make sure they are in the OFF status.
3	PM Numbers Error	<ol style="list-style-type: none"> 1. Incorrect configuration of wall-mounted module quantity in the LCM. 2. The wall-mounted modules have repeated IDs. 	<ol style="list-style-type: none"> 1. Compare the wall-mounted module quantity with the setting of PM Number in the LCM. 2. Check the DIP switches of every wall-mounted module.
4	Fuse Blowout	The input fuse is broken.	Please contact service personnel.
5	Ambient OTP	<ol style="list-style-type: none"> 1. The air vents are blocked. 2. The fans do not work. 3. The IGBT is damaged. 	Please contact service personnel.
6	BUS OVP/UVP	Failure of BUS capacitor.	Please contact service personnel.
7	Fan Fail	Failure of fans.	Please contact service personnel.

Item	Abnormality	Possible Cause	Solution
1	No current compensation	The CT is not well connected.	Check if the CT wiring is correct.

Chapter 8 : Warranty

Seller warrants this product, if used in accordance with all applicable instructions, to be free from original defects in material and workmanship within the warranty period. If the product has any failure problem within the warranty period, Seller will repair or replace the product at its sole discretion according to the failure situation.

This warranty does not apply to normal wear or to damage resulting from improper installation, operation, usage, maintenance or irresistible force (i.e. war, fire, natural disaster, etc.), and this warranty also expressly excludes all incidental and consequential damages.

Maintenance service for a fee is provided for any damage out of the warranty period. If any maintenance is required, please directly contact the supplier or Seller.



WARNING!

The individual user should take care to determine prior to use whether the environment and the load characteristic are suitable, adequate or safe for the installation and the usage of this product. The User Manual must be carefully followed. Seller makes no representation or warranty as to the suitability or fitness of this product for any specific application.

No. 501327990000
Version : V 0.0
Release Date : 2019_12_27

